

# Unlocking unit pneumatic

## FB-ENT-NDH-P

Item 116285



GO TO PRODUCT

ingun®

Partner for Future Technology

- Automated unlocking of closed pressure frame
- Quick, easy installation either on the side profile of the frame or on the pressure plate
- Simple adaptation to the pneumatic control system of the automatic opener/closer for vacuum test fixtures
- Pneumatic drive system

NEW

### Application

The functional unit is used for the automated unlocking of closed pressure frames. It can be mounted either on the side profile of the frame or on the pressure frame plate. It features a solenoid valve and other pneumatic components that can be connected directly to the pneumatic control system.

### Delivery

The product must be assembled upon delivery. Solenoid valve and other pneumatic components are included.

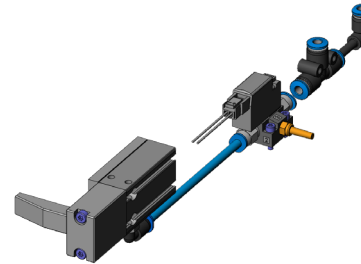

#### Note:

When operating the unlocking unit in conjunction with the automatic opener/closer mechanism for vacuum test fixtures, there are potential risks for the operator that must be eliminated by using suitable protective devices to ensure safe operation.

#### Note:

Customers are fully responsible for the professional installation of the functional unit. INGUN cannot accept any liability for damage resulting from incorrect installation, failure to observe the instructions in the documentation provided or failure to operate the test fixture or in a suitable test environment.

### General data

Product group:	Automation
Series:	FB-VAxxxx
Type:	Unlocking unit for pressure frame
Version:	Pneumatic
Accessory type:	Additional function
Scope of delivery:	Unassembled
Width:	48 mm [1.88 in]
Height:	29 mm [1.14 in]
Weight:	0.01 kg [0.022 lbs]
Min. temperature:	10 °C [50 °F]
Max. temperature:	60 °C [140 °F]
RoHS-compliant:	Yes

### Compatible with

Vacuum test fixtures (VA):	VA 20xx
Accessories:	ZSK

### Technical data

Stroke:	10 mm [.393 in]
Connection:	Compressed air, 6 bar
Force:	31 N [111 ozf]
Compressed air connection:	QS-4
Length:	74 mm [2.91 in]
Outer dimensionS (WxDxH):	48 x 74 x 29 mm [1.88 x 2.91 x 1.14 in]



GO TO PRODUCT

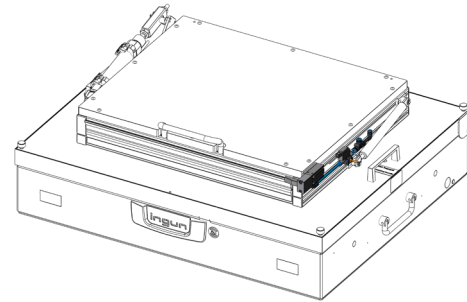
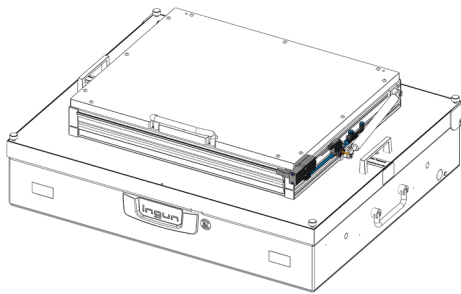

### Accessories

Part no.	Designation	Version
115857	FB-OSA-P-ZSK/VKH/NDH	Automatic opener/closer unit for vacuum test fixtures
115870	FB-STP-OSA-ZSK/VKH/NDH	Pneumatic control for automatic opener/closer unit for vacuum test fixtures

### INGUN Prüfmittelbau GmbH

Max-Stromeyer-Straße 162  
78467, Constance, Germany  
Phone +49 7531 8105-0  
Customer hotline +49 7531 8105-888  
Fax +49 7531 8105-65  
info@ingun.com



Learn more about  
Test fixture kits

