

Vacuum test fixture

VA 4060T/D/H/PYLON-12

Item 114625



GO TO PRODUCT

ingun®

Partner for Future Technology

- Vacuum test fixture with parallel lifting vacuum cassette
- Robust, maintenance-friendly design with outstanding service life
- Increased ease of use thanks to simple, intuitive handling
- Easy access to housing interior thanks to wide opening angle
- Vacuum cassette can be upgraded for dual-stage contacting
- For the assembly of items delivered unassembled, Refer to the drawings of the items specified in the parts list to assemble items

Application

Typical service life of tip is approximately 25,000 load cycles (laboratory conditions)

Version

- 10 mm thick, deflection-resistant probe plate (KTP) made of FR4
- Incl. 6 mm thick moving plate (ADP) with ESD-conductive surface, including 4 captive screws
- Tool-free access to the probe plate (KTP) to replace worn test probes easily
- Housing to be opened with tool (TORX T20)
- Foldable bow handles for safe, easy transport.

Delivery

The product is delivered partially assembled. The housing is fully assembled. The vacuum cassette with components to be reworked for a DUT-specific customisation must be assembled upon delivery.

General data

Test system interface:	GeDis Pylon
Product group:	Vacuum test fixture (VA)
Main series:	VA xxxx
Subseries:	VA 40xx
Series:	VA 4060T
Size:	xx60T
Test fixture type:	Tandem stand-alone test fixture
Contact stroke generation:	Vacuum
Housing type:	Desk housing
Contacting direction:	1-stage / 2-stage
Max. contact force:	10000 N [35,969 ozf]
Approx. parallel contact stroke:	12.8 mm [.503 in]
Weight:	16.9 kg [37.2 lbs]
Min. temperature:	10 °C [50 °F]
Max. temperature:	60 °C [140 °F]
RoHS-compliant:	Yes

NEW

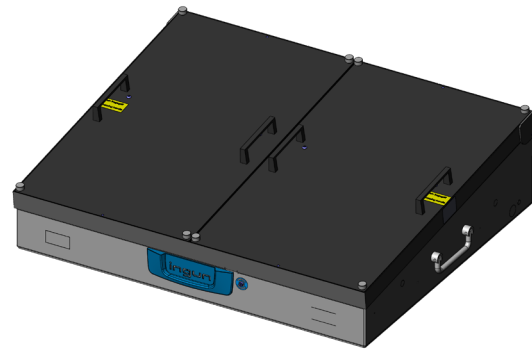

Note:

The customising guidelines document INFO 4630 should be referred to for the professional customisation of VA 40xx test fixtures for single-stage contacting. For dual-stage contacting customisation, please refer to customising guidelines document INFO 4638.

Technical data

Test probe installation height, bottom:	16 mm [.629 in]
Test probe installation height, dual-stage, bottom:	21.3 mm [.838 in]
Force of gas pressure springs:	400 N (L: 200 N / R: 200 N)
Standard version:	Yes
Useable area, standard (WxD):	2 x 225 x 430 mm [.078 x 8.85 x 16.9 in]
ESD version:	No
Radio frequency version:	No
Rigid pin version:	No
Dual-stage version:	Yes, with compatible additional option
Useable area, dual-stage (WxD):	2 x 205 x 430 mm [.078 x 8.07 x 16.9 in]
Additional contacting unit (ZSK), top:	Yes, with suitable additional option
Outer dimensions, closed (WxDxH):	675 x 600 x 176 mm [26.5 x 23.6 x 6.92 in]

Vacuum test fixture VA 4060T/D/H/PYLON-12

Item 114625



GO TO PRODUCT

ingun[®]

Partner for Future Technology

Housing perforations and pilot holes

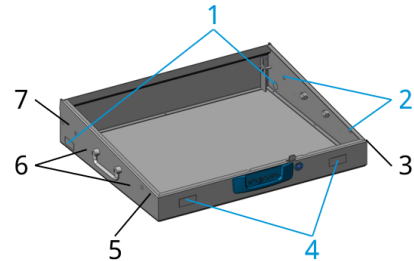
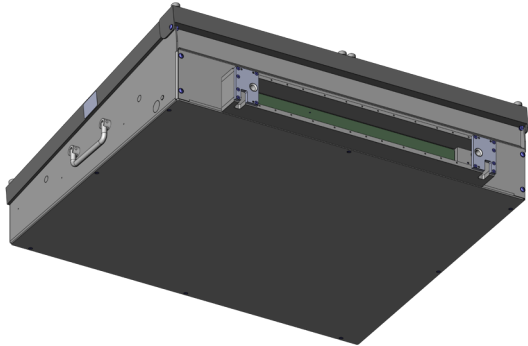

Perforated for:

1. Cable connections
2. Additional handles
4. Stroke counter

Prepared for:

3. ESD discharge button
5. Anti-pinch protection
6. Alum-A handles
7. Earthing contact

Accessories

Part no.	Designation	Version
115013	FB-2VE-VA4060T	Dual-stage shifting unit
114555	VD-V-VA4060T-2	Vacuum seal external
107048	VD-Z-21-300-200-2	Vacuum seal vacuum-free zone (fixed dimensions)
109501	VD-Z-21-XXX-XXX-2	Vacuum seal vacuum-free zone (variable dimensions)
8078	GDF-305-120-200N-A6-A6	Gas pressure spring
105791	FED-10,0-24,5-103N-11,6	Pressure spring
2599	HBS-03,0-10,0	Stroke-limiting disk
116613	EHZ-08-R-11-TR	Electric stroke counter
113481	FB-TWA	Alum-A transport bracket
17036	FB-ALS-VAxxxx-2S	ESD discharge probe

INGUN Prüfmittelbau GmbH

Max-Stromeyer-Straße 162
78467, Constance, Germany
Phone +49 7531 8105-0
Customer hotline +49 7531 8105-888
Fax +49 7531 8105-65
info@ingun.com



Prices and delivery times on request.
Technical changes reserved. 05/26_GB

Learn more about
Test fixture kits

