

# Interface support

## SSA-VPC-G20X-MAxx13

Item 115674



GO TO PRODUCT

**ingun**<sup>®</sup>

Partner for Future Technology

- Interface support für VIRGINIA Panel G20x interface
- Ideally designed for MA xx13 test fixtures
- Quick, easy installation on the back of the test fixture
- Reliable connection from test fixture to system interface

### Application

The interface frame (SSA) is used for reliable connection of the interface (SST) to the test fixture.

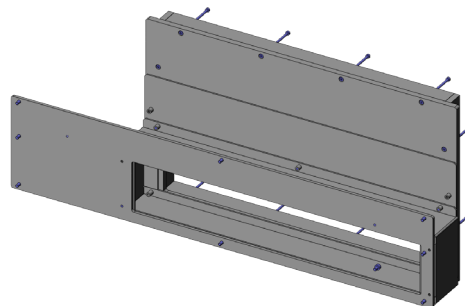

### General data

Product group:	Housing
Series:	SSA-MAxxxx
Type:	VPC-G20x (Virginia Panel)
Version:	MA xx13
Accessory type:	Additional function
Scope of delivery:	Unassembled
Width:	97 mm [3.81 in]
Height:	256.5 mm [10 in]
Weight:	3.1 kg [6.83 lbs]
Min. temperature:	10 °C [50 °F]
Max. temperature:	60 °C [140 °F]
RoHS-compliant:	Yes

### Compatible with

Manual test fixtures (MA):	MA xx13
Accessories:	SST-VPC-G20X

### Technical data

Length:	613 mm [24.1 in]
Outer dimensionS (WxDxH):	613 x 97 x 256.5 mm [24.1 x 3.81 x 10 in]

### INGUN Prüfmittelbau GmbH

Max-Stromeyer-Straße 162  
78467, Constance, Germany  
Phone +49 7531 8105-0  
Customer hotline +49 7531 8105-888  
Fax +49 7531 8105-65  
info@ingun.com



Prices and delivery times on request.  
Technical changes reserved. 05/26\_GB

Learn more about  
Test fixture kits

