

Board marker probe ME-P-S2,0-16-054-QS4

Item 25241



GO TO PRODUCT

ingun[®]

Partner for Future Technology

- Compact, robust design
- Precise, adjustable positioning
- Permanent marking of various materials
- Outstanding service life, highly resistant to wear
- Pneumatic drive system

INGUN SELECTION

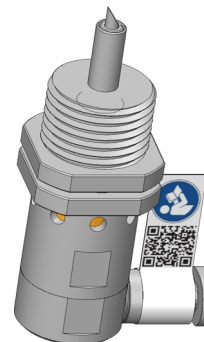

Application

The new ME-E board marker probe is used for reliable marking of tested electronic assemblies. It is installed in a test fixture or exchangeable kit, takes up little space, and can be precisely adjusted.

Function

The engraver is rotated using compressed air. At the same time, a lifting movement is performed so that the engraver is pressed onto the circuit board and permanently marks the test specimen via the rotary movement. As soon as the compressed air is switched off, the engraver is returned to its home position by the internal spring.

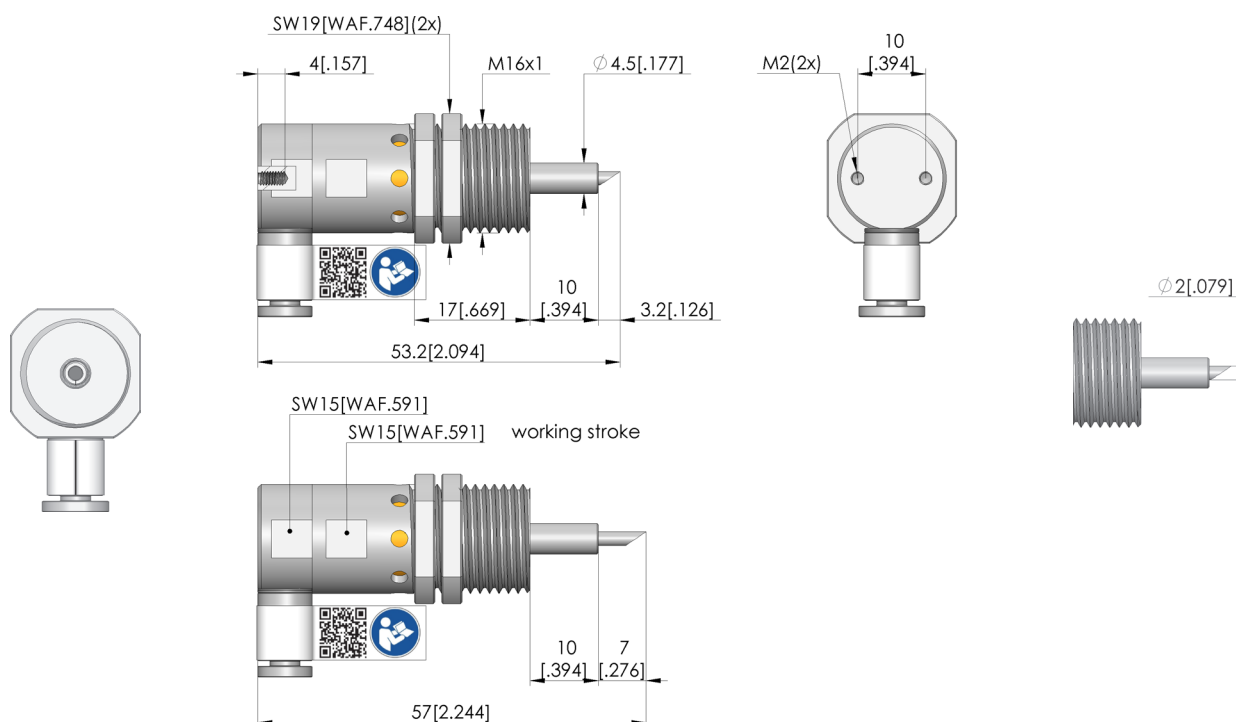

General data

Product group:	Board marker probes (ME)
Series:	ME-P
Version:	Pneumatic
Accessory type:	Customising accessories
Outer dimensions (TxL):	16 x 54 mm [.629 x 2.12 in]
Outer thread:	M16 x 1
Lock nut width across flats:	19 mm [.748 in]
Marking type:	Circle
Approx. marking Ø:	2 mm [.078 in]
Surface material:	Hard / soft
Weight:	0.07 kg [.154 lbs]
Min. temperature:	-30 °C [-22 °F]
Max. temperature:	80 °C [176 °F]
RoHS-compliant:	Yes

Compatible with

Manual test fixtures (MA):	MA 20xx
Vacuum test fixtures (VA):	VA xxxx
MA exchangeable kits (ATS MA):	
VA exchangeable kits (ATS VA):	ATS VINxxx
PA exchangeable kits (ATS PA):	ATS PAZxxx

BOARD MARKER PROBES

Board marker probe ME-P-S2,0-16-054-QS4

Item 25241



GO TO PRODUCT

ingun[®]

Partner for Future Technology

Technical data

Recommended working stroke:	2 mm [.078 in]
Recommended marking impulse:	.5 – .1 s
Maximum stroke (ME):	3.5 mm [.137 in]
Approx. compression at working stroke:	2 N [7.19 ozf]
Operating pressure:	6 bar [87 psi]
Operating medium:	Compressed air filtered, without oiled compressed air
Marking tip:	Cutting engraver
Engraver material:	Solid carbide
Approx. engraver hardness:	1600 HV
Compressed air connection:	QS-4
Max. filter gauge:	0.04 mm [1.57 mil]
Min. normal rated flow:	100 l/min [26.4 gal/min]
Drive:	Compressed air motor
Motor connection via:	Compressed air connection
Approx. idle speed:	27,000 U/min
Noise emission:	90 dB measured at 1m intervals

Test Tabelle von Andi DE

A1	B1	C1
A2	B2	C2
A3	B3	C3

INGUN Prüfmittelbau GmbH

Max-Stromeyer-Straße 162
78467, Constance, Germany
Phone +49 7531 8105-0
Customer hotline +49 7531 8105-888
Fax +49 7531 8105-65
info@ingun.com



Prices and delivery times on request.
Technical changes reserved. 07/26_GB

Learn more about
Board marker probes



BOARD MARKER PROBES

ingun.com