

Dual-stage shifting unit

FB-2VE-VA4060T

Item 115013



GO TO PRODUCT

ingun[®]

Partner for Future Technology

Application

Dual-stage shifting unit for vacuum test fixture VA 40xx to create dual-stage contacting (ICT/FCT)

Note:

Two dual-stage shifting units are required for tandem operation

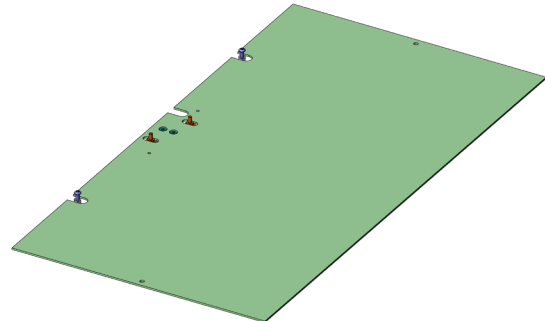

General data

Product group:	Functional units
Series:	FB-VAxxxx
Type:	Electric shifting unit
Version:	Dual-stage
Accessory type:	Customising accessories
Scope of delivery:	Unassembled
Width:	240 mm [9.44 in]
Height:	60 mm [2.36 in]
Weight:	0.4 kg [.881 lbs]
Min. temperature:	10 °C [50 °F]
Max. temperature:	60 °C [140 °F]
RoHS-compliant:	Yes

Compatible with

Vacuum test fixtures (VA): VA 4060T

Technical data

Max. voltage:	12 VDC
Useable area (WxD):	205 x 430 mm [8.07 x 16.9 in]
Length:	462 mm [18.1 in]
Outer dimensionS (WxDxH):	240 x 462 x 60 mm [9.44 x 18.1 x 2.36 in]

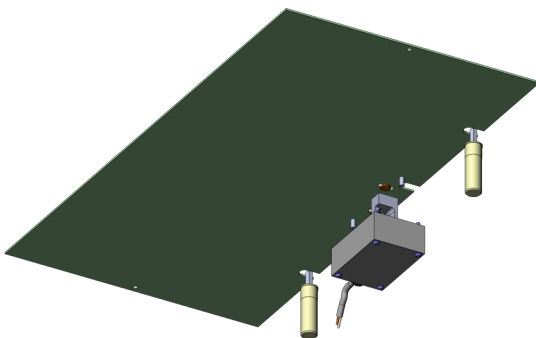

INGUN Prüfmittelbau GmbH

Max-Stromeyer-Straße 162
78467, Constance, Germany
Phone +49 7531 8105-0
Customer hotline +49 7531 8105-888
Fax +49 7531 8105-65
info@ingun.com



Prices and delivery times on request.
Technical changes reserved. 05/26_GB

Learn more about
Test fixture kits

