

Shock-proof plate FB-BSP-ATMA11

Item 41811



GO TO PRODUCT

ingun[®]

Partner for Future Technology

- Upgrade kits to make operation easier, increase the testing reliability, and to reduce handling times
- Available for manual test fixtures and exchangeable kits
- Wide range of varying functions

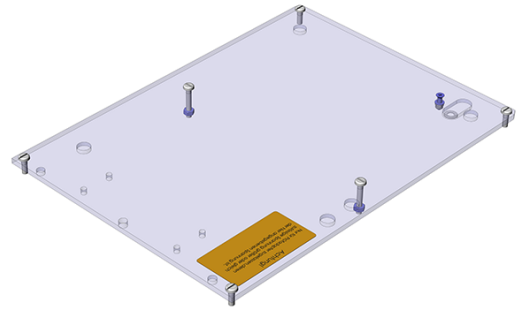

General data

Product group:	Protective earth wiring / shock-proof protection
Series:	FB-ATMAxx
Accessory type:	Additional function
Width:	210 mm [8.26 in]
Height:	4 mm [.157 in]
RoHS-compliant:	Yes

Compatible with

Exchangeable kits version:	No RF
MA exchangeable kits (ATS MA):	ATS MA11

Technical data

Length:	290 mm [11.4 in]
Outer dimensionS (WxDxH):	210 x 290 x 4 mm [8.26 x 11.4 x .157 in]

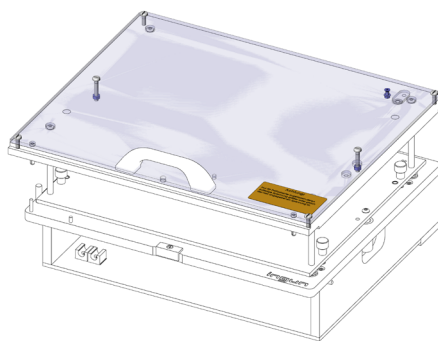

INGUN Prüfmittelbau GmbH

Max-Stromeyer-Straße 162
78467, Constance, Germany
Phone +49 7531 8105-0
Customer hotline +49 7531 8105-888
Fax +49 7531 8105-65
info@ingun.com



Prices and delivery times on request.
Technical changes reserved. 05/26_GB

Learn more about
MA functional units

