

# Board marker probe ME-E-R2,0-08-053-2S-BL6V-42V

Item 107376



GO TO PRODUCT

ingun®

Partner for Future Technology

- Short, compact design
- Marking tip with a new dual scratching engraver
- Precise, adjustable positioning
- Quick-exchange engraving unit
- Operating voltage from 6 V to 42 V
- Permanent marking of various materials
- Outstanding service life, highly resistant to wear
- Typical extraction force from receptacle: 3 N to 9.5 N

INGUN SELECTION

INGUN  
PATENT

NEW

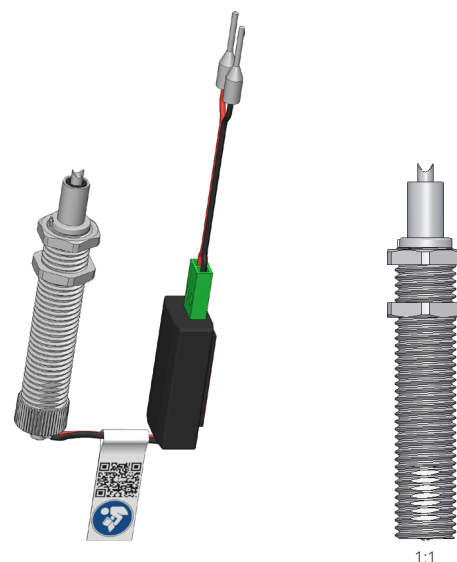

## Application

The new ME-E board marker probe is used for reliable marking of tested electronic assemblies. It impresses not only with its extremely short, compact design, but also with its above-average functionality. It is installed in a test fixture or exchangeable kit, takes up little space, and can be precisely adjusted.

## Function

The spring-loaded marking engraver is pressed against the surface of the PCB during the test. The marking unit is supplied with current in the contacted state. The rotary movement generated by the current marks the PCB permanently.

## Construction

The board marker probe consists of an engraving unit with dual scratching engraver, a receptacle, and a connection cable.

### Note:

When replacing the engraving unit, make sure that the slot on the engraving unit is aligned with the anti-rotation anchor on the receptacle as shown by the arrow. The engraving unit must be inserted as far as it will go.

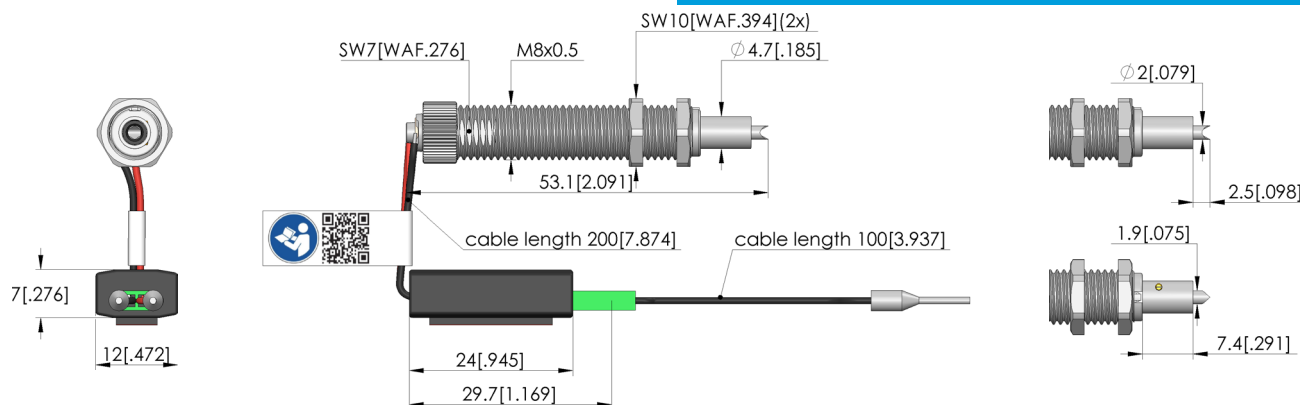

# Board marker probe

## ME-E-R2,0-08-053-2S-BL6V-42V

Item 107376



GO TO PRODUCT

**ingun**<sup>®</sup>

Partner for Future Technology

### General data

Product group:	Board marker probes (ME)
Series:	ME-E
Version:	Electrical
Accessory type:	Customising accessories
Outer dimensions (TxL):	8 x 53 mm [.314 x 2.08 in]
Outer thread:	M8 x 0,5
Lock nut width across flats:	10 mm [.393 in]
Marking type:	Circle
Approx. marking Ø:	2 mm [.078 in]
Surface material:	Hard / soft
Weight:	0.02 kg [.044 lbs]
Min. temperature:	10 °C [50 °F]
Max. temperature:	60 °C [140 °F]
RoHS-compliant:	Yes

### Compatible with

Manual test fixtures (MA):	MA 20xx
Vacuum test fixtures (VA):	VA xxxx
MA exchangeable kits (ATS MA):	
VA exchangeable kits (ATS VA):	ATS VINxxx
PA exchangeable kits (ATS PA):	ATS PAZxxx

### Technical data

Recommended working stroke:	1 mm [.039 in]
Recommended marking impulse:	1 s
Maximum stroke (ME):	1.6 mm [.062 in]
Approx. compression at working stroke:	3 N [10.7 ozf]
Marking tip:	Double-tip scratching engraver
Engraver material:	Solid carbide
Approx. engraver hardness:	1600 HV
Drive:	Electric gear motor
Motor connection via:	Plug connector
Rated voltage:	12 V DC
Rated output:	.12 W
No-load current:	5 mA
Starting current:	25 mA
Max. load current:	10 mA
Max. torque:	29 mNm [.256 lbf·in]
Approx. idle speed:	138 U/min
Noise emission:	

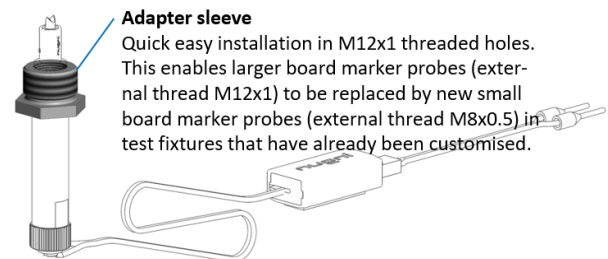
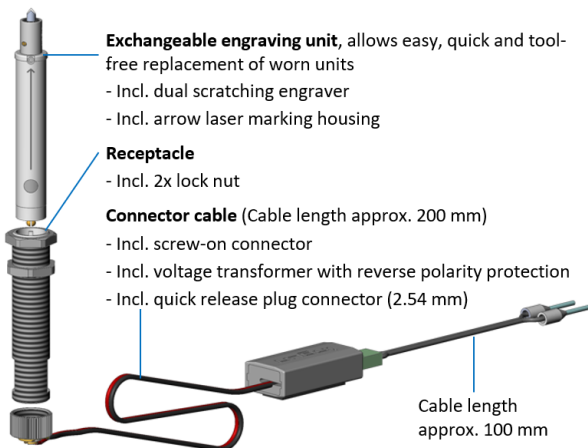
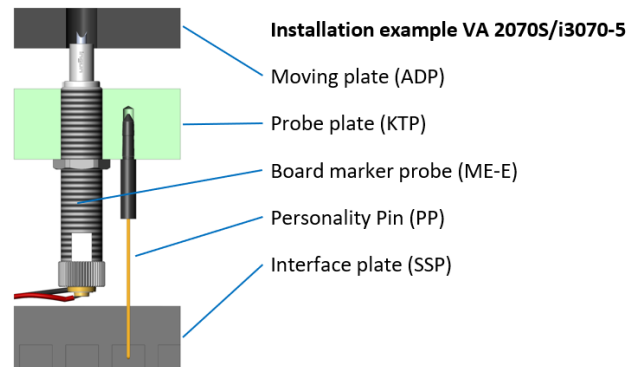
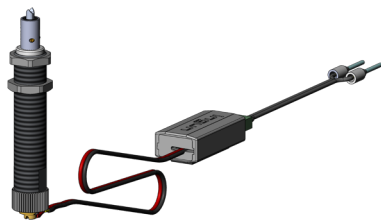

BOARD MARKER PROBES

# Board marker probe ME-E-R2,0-08-053-2S-BL6V-42V

Item 107376



GO TO PRODUCT

**ingun**<sup>®</sup>

Partner for Future Technology

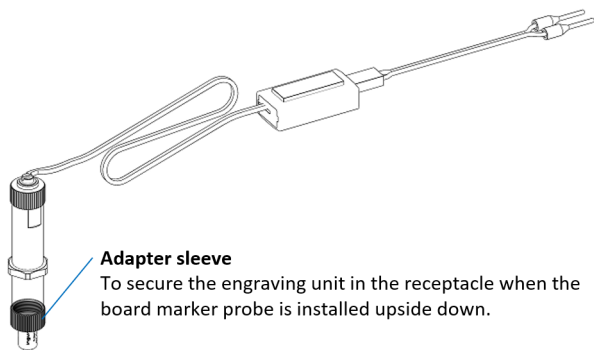

#### Adapter sleeve

To secure the engraving unit in the receptacle when the board marker probe is installed upside down.

## Replacement parts & Accessory

Part no.	Designation	Version
Replacement parts		
107374	GE-E-R2,0-07-050-2S-SK3V	Dual scratching engraver, for use exclusively in the receptacle
110672	KTH-ME-D7-M8-SW7	Receptacle with 2x lock nut
109474	ASK-ME-G-325-AWG20-002	Connector cable with screw-on connector, voltage transformer, and plug connector
112682	SWS-ME-E-R2,0-2S	Engraver change set, dual scratching engraver for markings with D = 2.0 mm (without pressure spring 108769)
114257	SWS-ME-E-R1,0-2S	Engraver change set, dual scratching engraver for markings with D = 1.0 mm (without pressure spring 108769)
Accessory		
108441	ADH-ME-M8-M12-SW14	Adapter sleeve (DI = M8x0.5, DA = M12x1, H = 9.5 mm, SW = 14)
109138	ADH-ME-M8-R	Adapter sleeve (DI = M8x0.5   DA = 9.0 mm   H = 5.0 mm   Knurl)

## INGUN Prüfmittelbau GmbH

Max-Stromeyer-Straße 162  
78467, Constance, Germany  
Phone +49 7531 8105-0  
Customer hotline +49 7531 8105-888  
Fax +49 7531 8105-65  
info@ingun.com



Prices and delivery times on request.  
Technical changes reserved. 06/26\_GB

Learn more about  
Board marker probes



BOARD MARKER PROBES

ingun.com