

Montageanleitung

Sicherheits-Kontaktleiste – FB-SIS-SOA-MAxxxx

Assembly Instructions

Safety switch - FB-SIS-SOA-MAxxxx

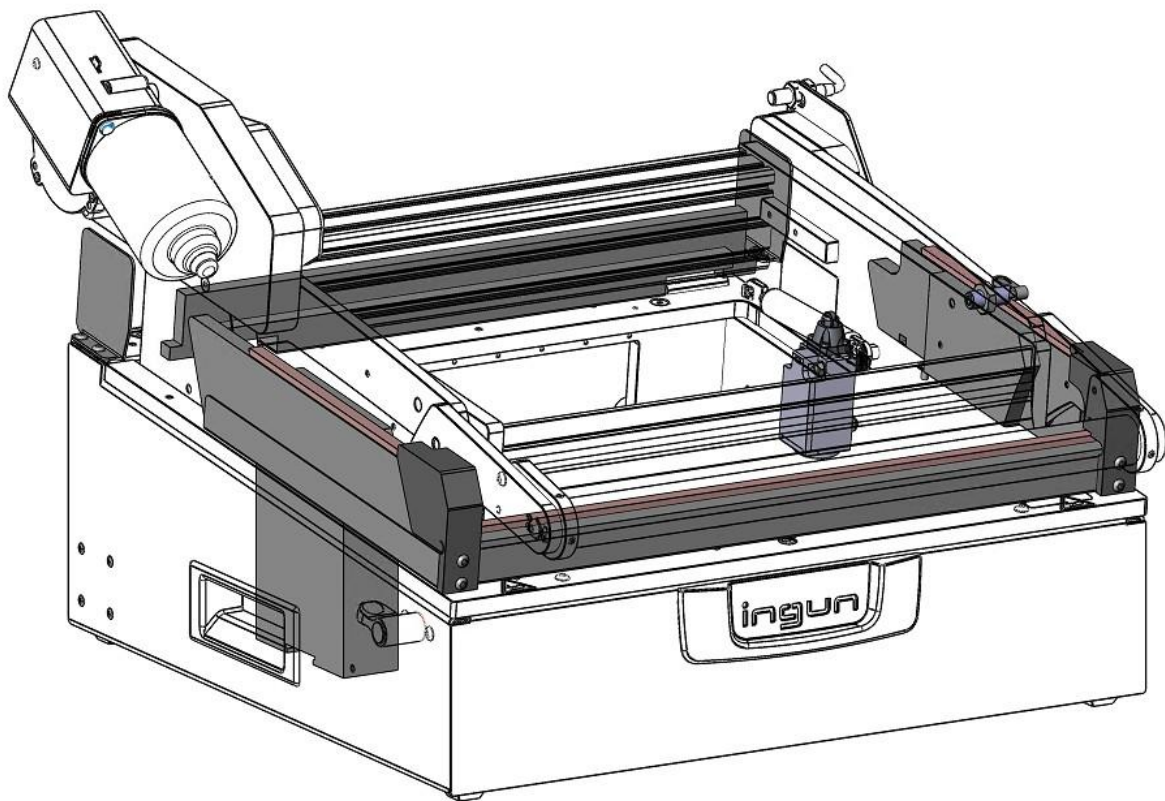











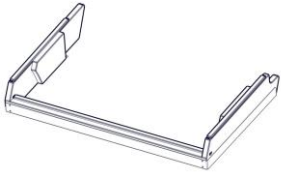



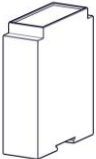



INFO 4596 Index 8

Das Referenzdesign als Vorschlag für die Steuerung dieser Funktionsbaugruppe finden Sie unter: www.ingun.com/manuals/INGUN_INFO-4594.pdf

Suggestions for the control of this functional unit can be found in the reference design document INFO 4594: www.ingun.com/manuals/INGUN_INFO-4594.pdf.



Teileliste / *Parts list*

<p>1 1 Stück/Piece</p> 	<p>2 1 Stück/Piece</p> 	<p>3 1 Stück/Piece</p> 
<p>4 2 Stück/Piece</p> 	<p>5 1 Stück/Piece</p> 	<p>6 1 Stück/Piece</p> 
<p>7 2 Stück/Piece</p>  <p>Abstandsrolle 6,2 x 7</p>	<p>8 3 Stück/Piece</p>  <p>DIN 125 - 4,3</p>	<p>9 3 Stück/Piece</p>  <p>DIN 934 - M4</p>
<p>10 2 Stück/Piece</p>  <p>ISO 7380 - M4 x 35 - T20</p>	<p>11 1 Stück/Piece</p>  <p>ISO 7380 - M4 x 10 - T20</p>	<p>12 10 Stück/Piece</p>  <p>ISO 7380 - M4 x 6 - T20</p>
<p>13 1 Stück/Piece</p>  <p>ISO 14579 - M4 x 8 T20</p>	<p>14 2 Stück/Piece</p>  <p>DIN 7991 - M5 x 20</p>	<p>15 1 Stück/Piece</p>  <p>ISO 8734 - 2 x 12</p>
<p>16 1 Stück/Piece</p>  <p>Rastbolzen / Locking bolt</p>	<p>17 1 Stück/Piece</p>  <p>Schaltwippe links / Left-hand rocker switch</p>	<p>18 1 Stück/Piece</p>  <p>Schaltwippe rechts / Right-hand rocker switch</p>

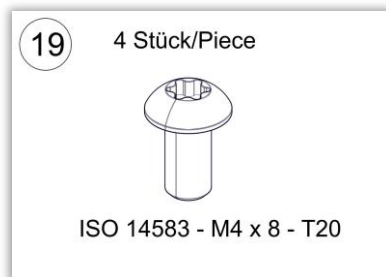

1) Bearbeitung Montageplatte / Processing mounting plate

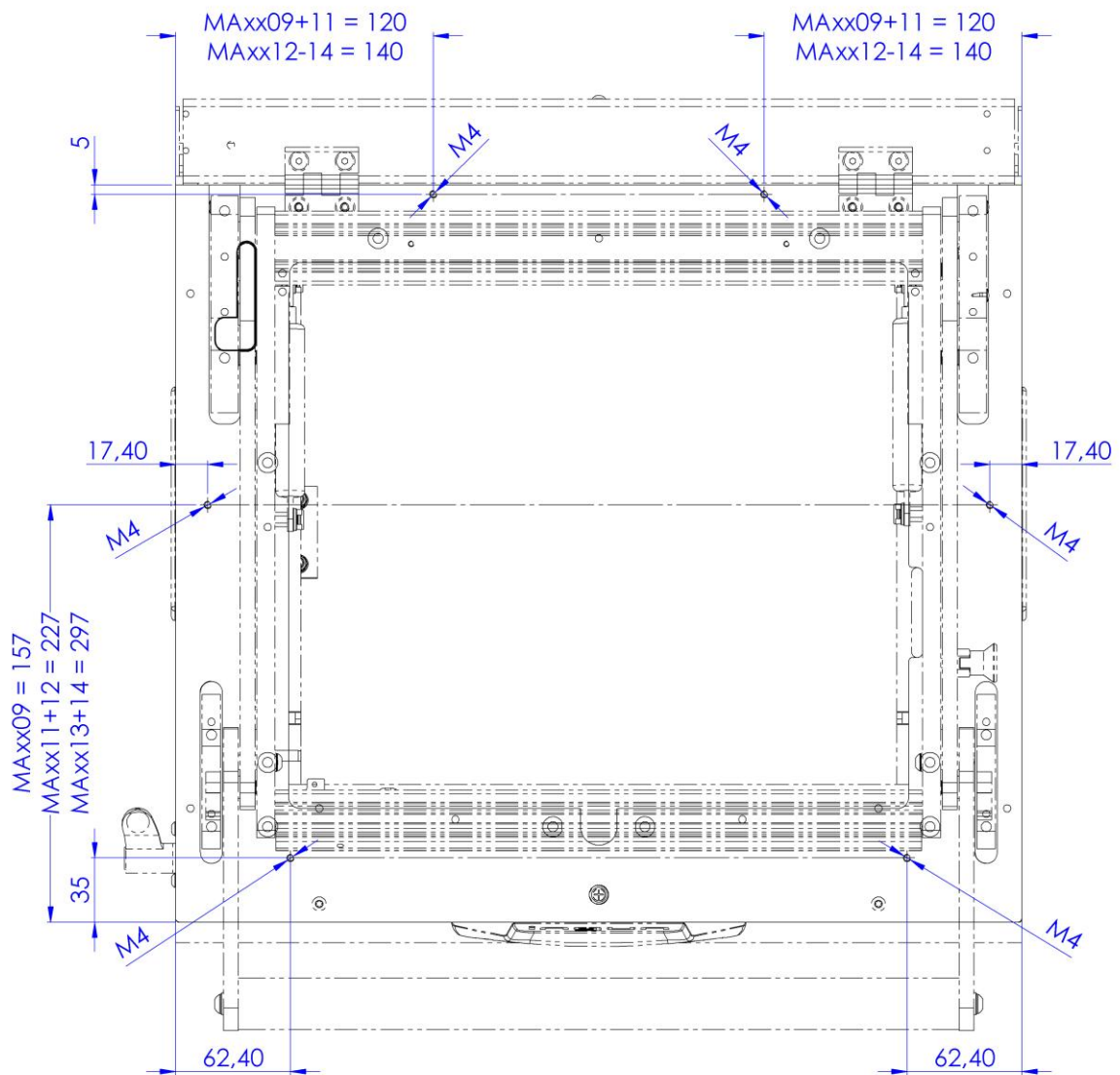

2) Bearbeitung Gehäuse seitlich / Processing of housing on the side

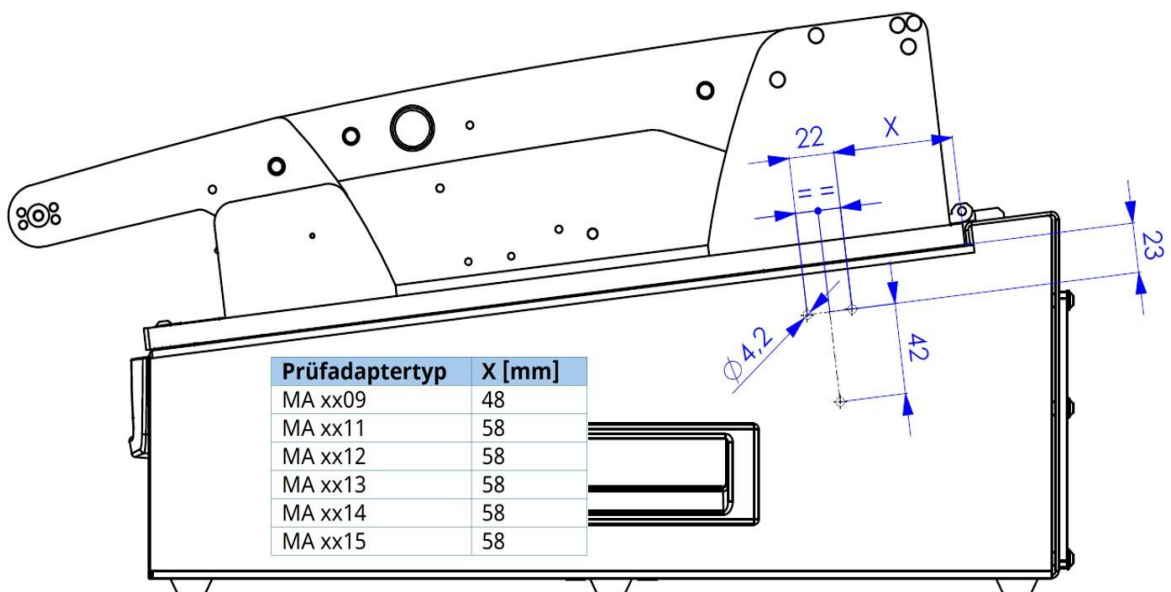

3) **Bearbeitung Gehäuse oben / Processing of the housing at the top**

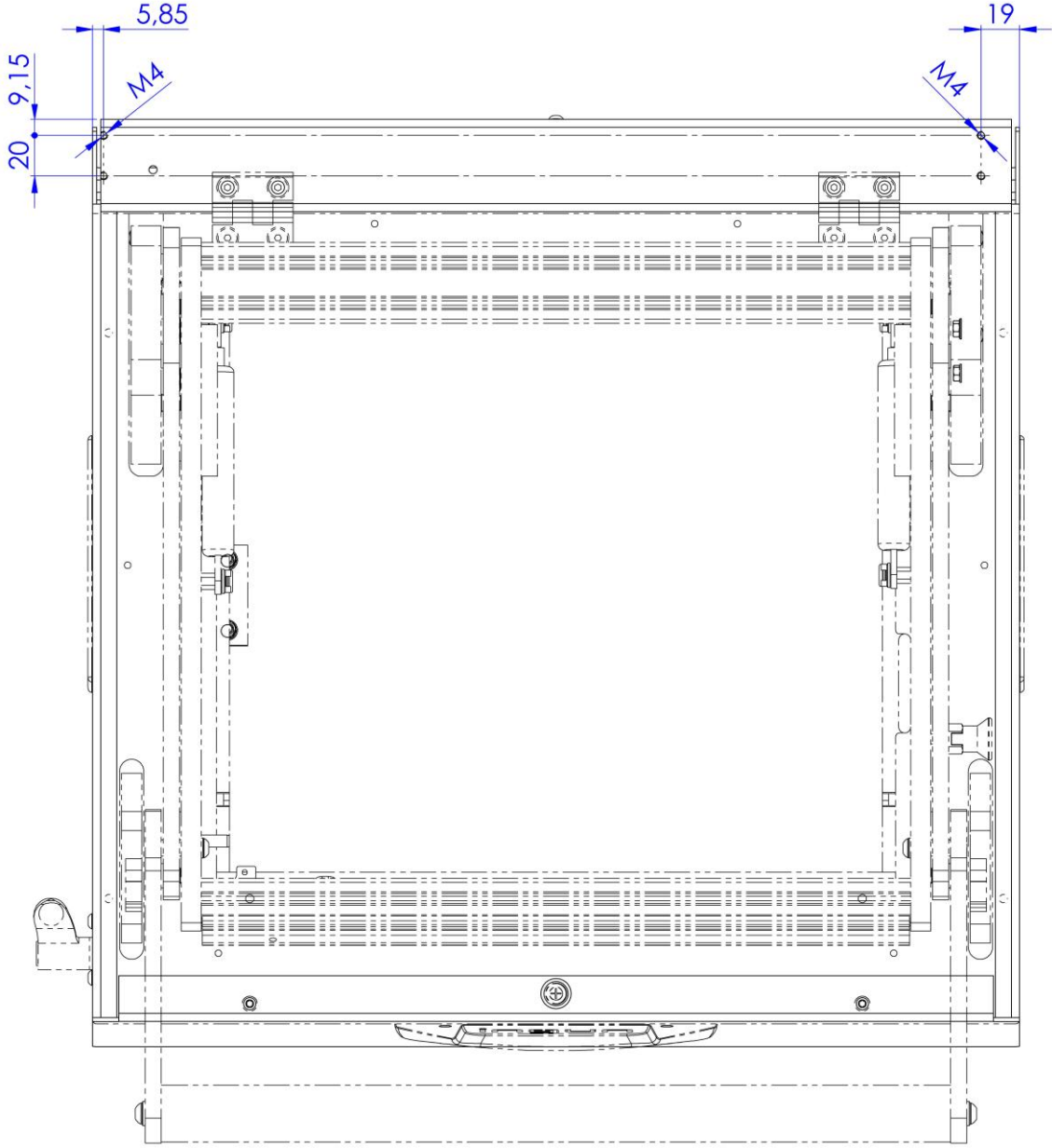

4) Zahnrad für freie Bewegung entfernen
Remove gear wheel for free movement

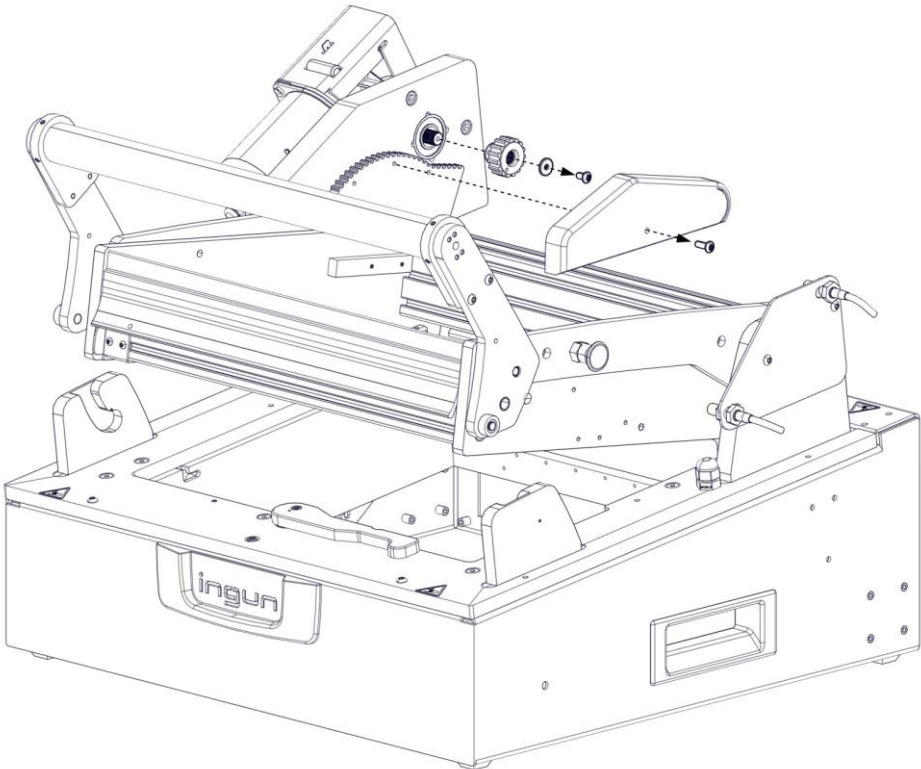

5)

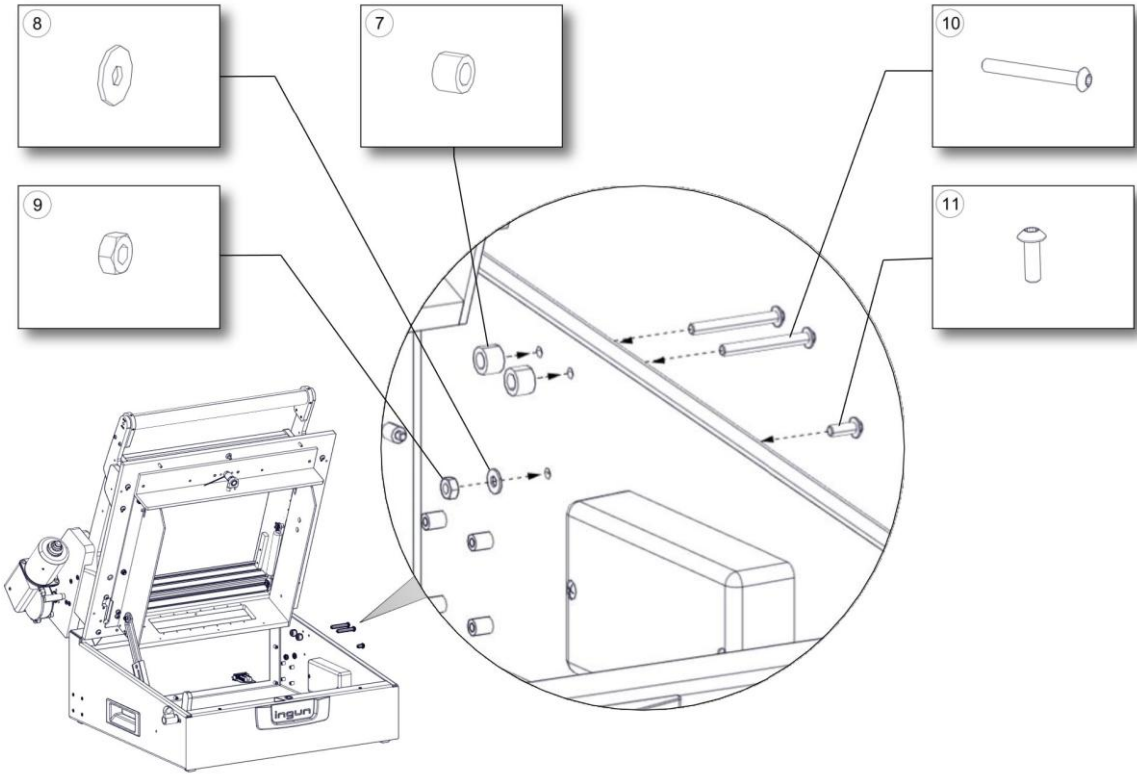

6)

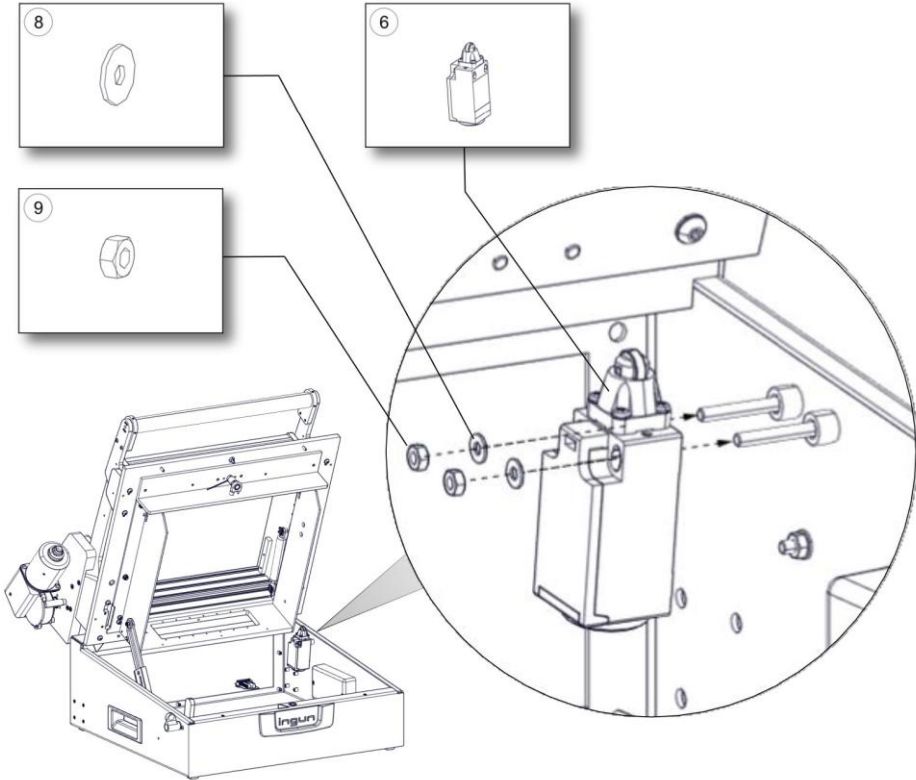

7)

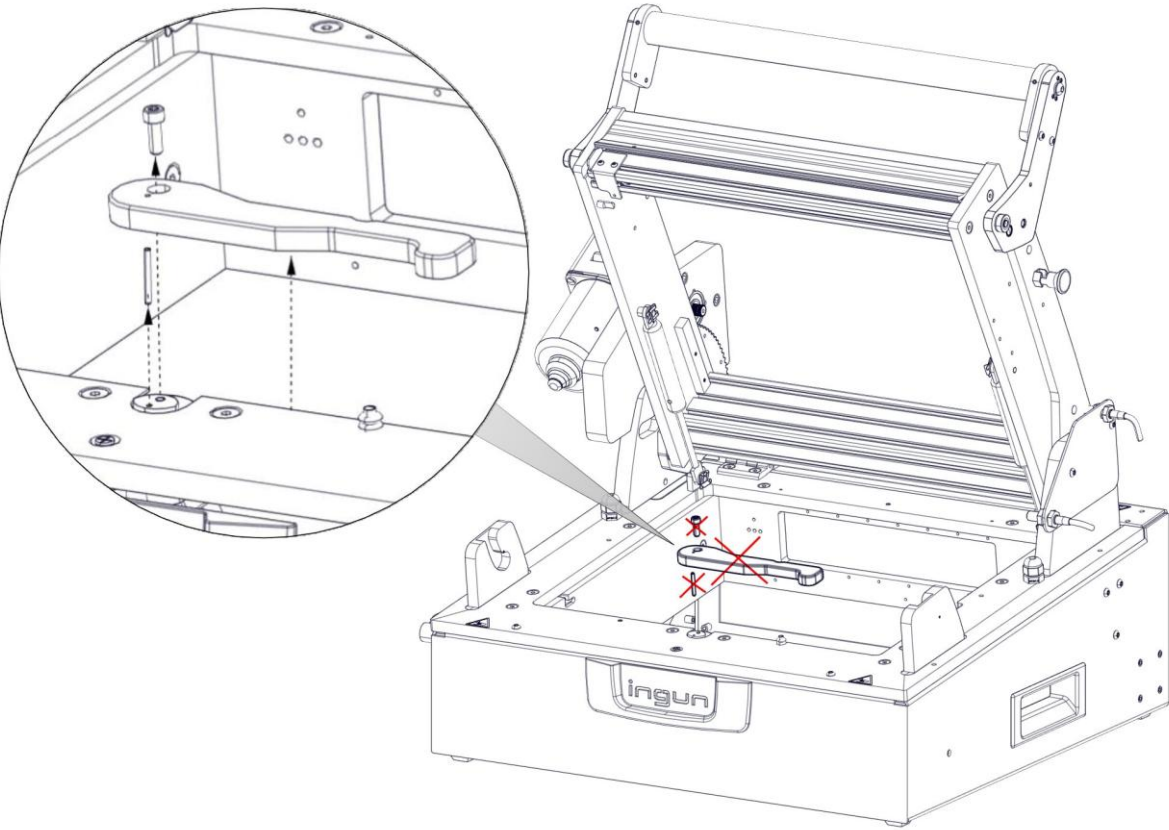

8)

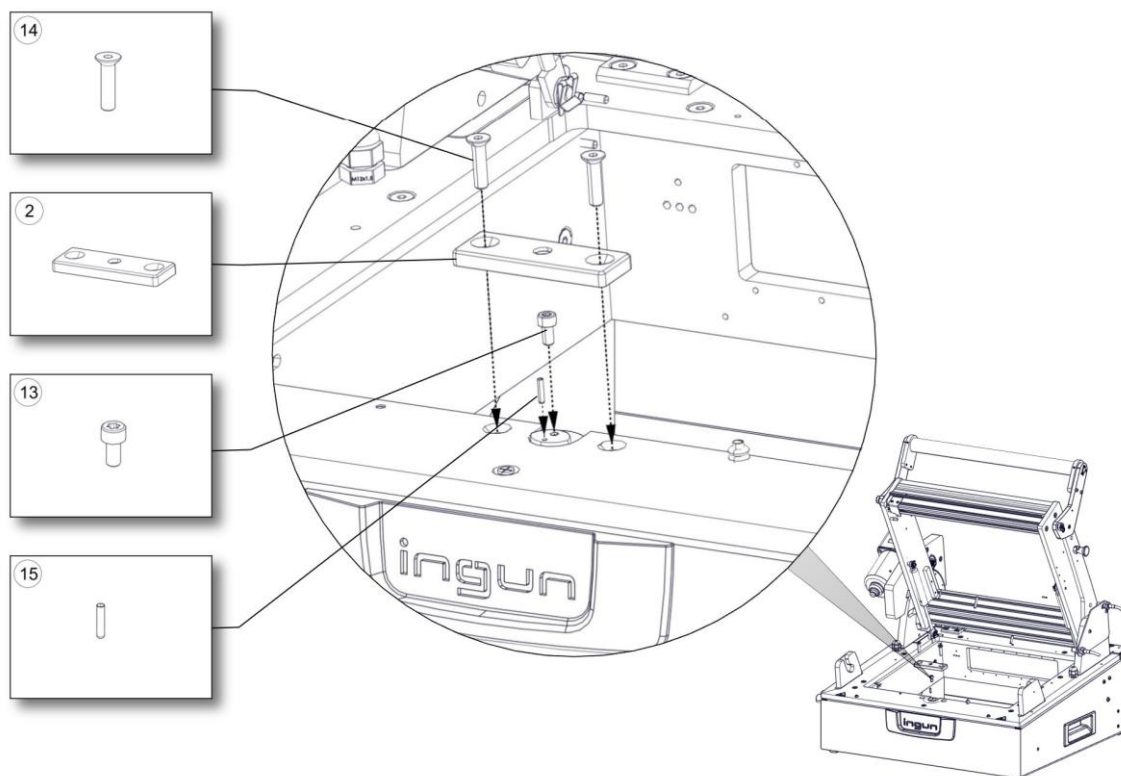

9) **Vorspannen der Feder für den Exzenter**
Pre-load the spring for the eccentric tappet

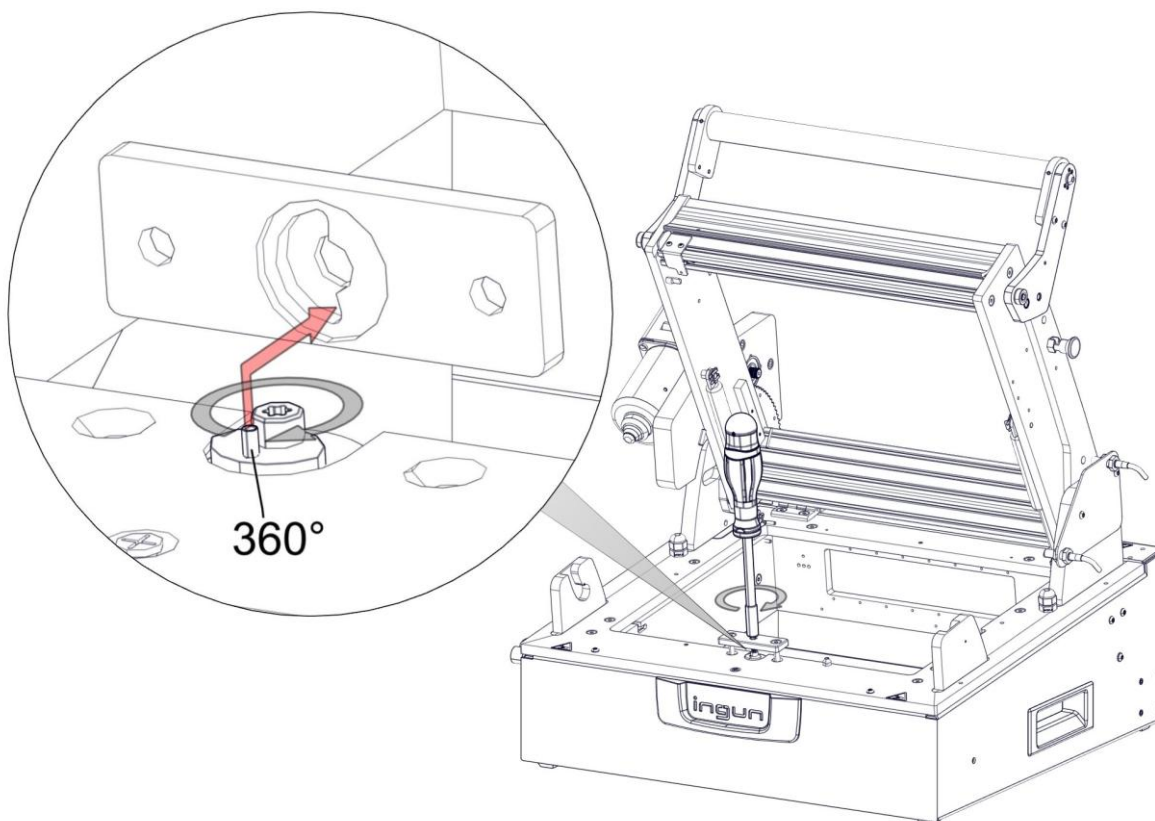

10)

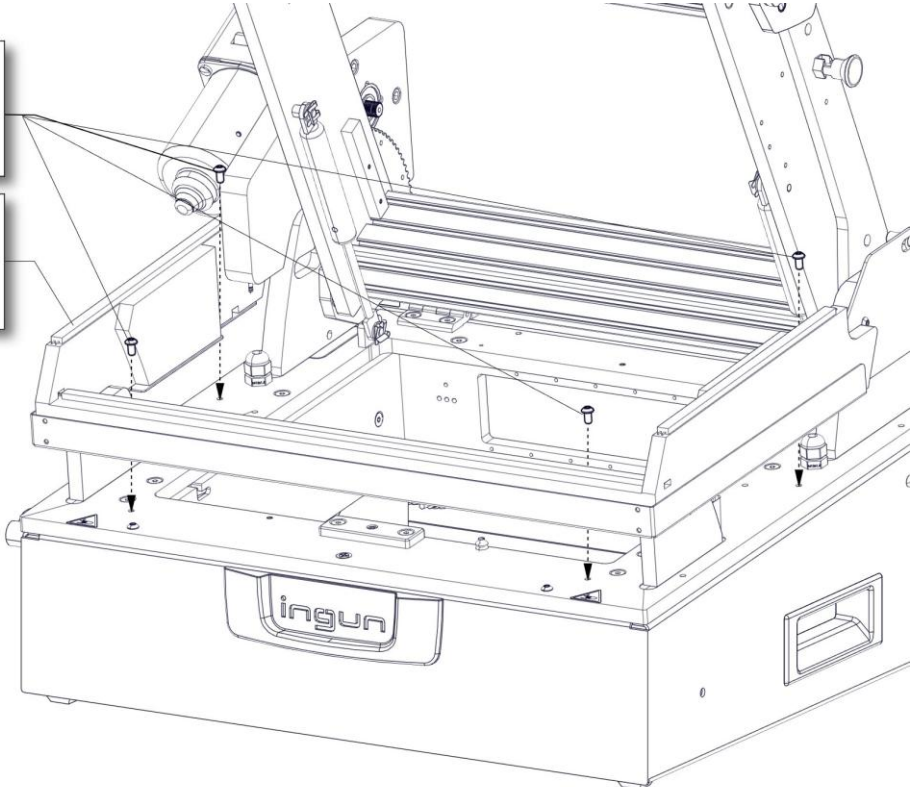
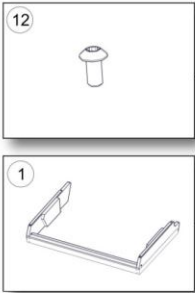

11)

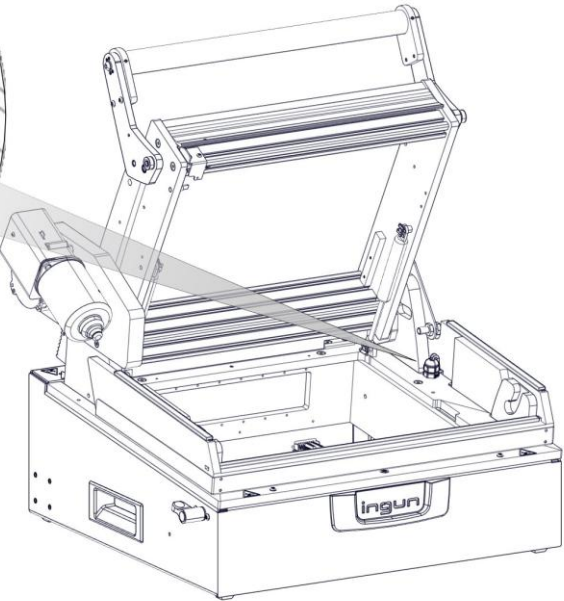
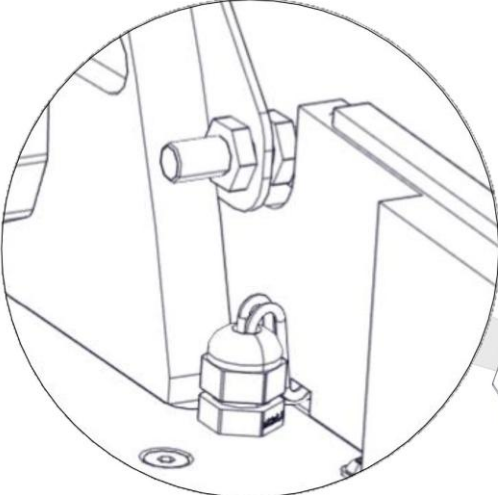

12)

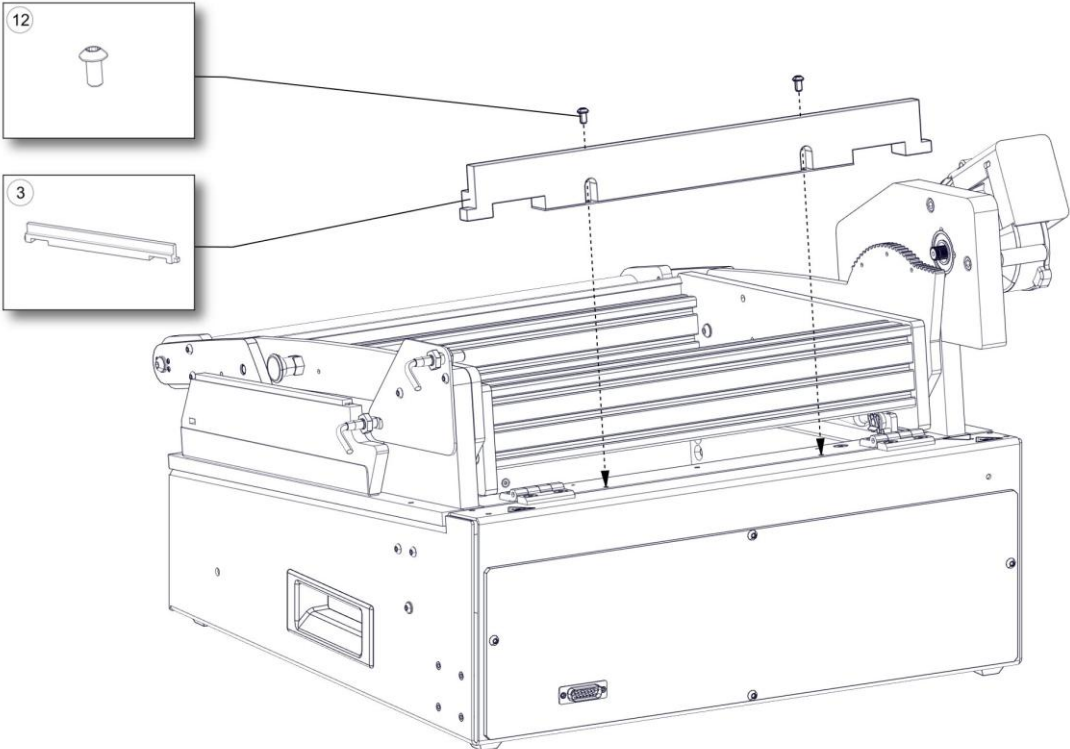

13)

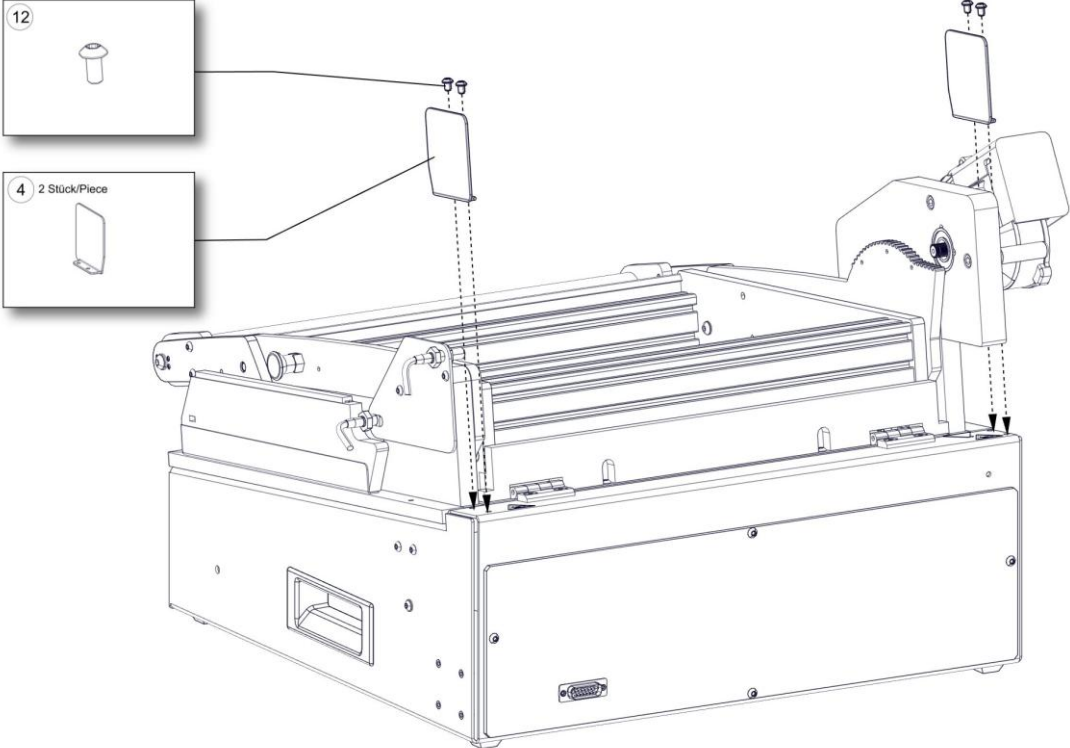

14)

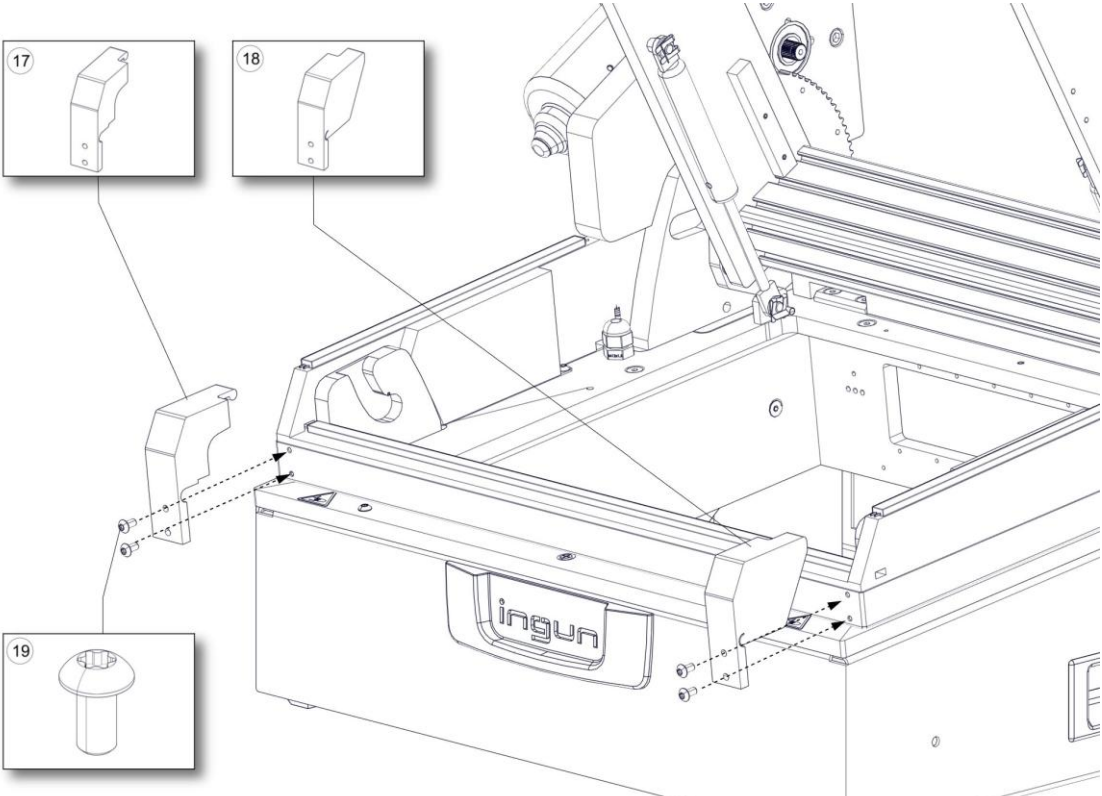

15)

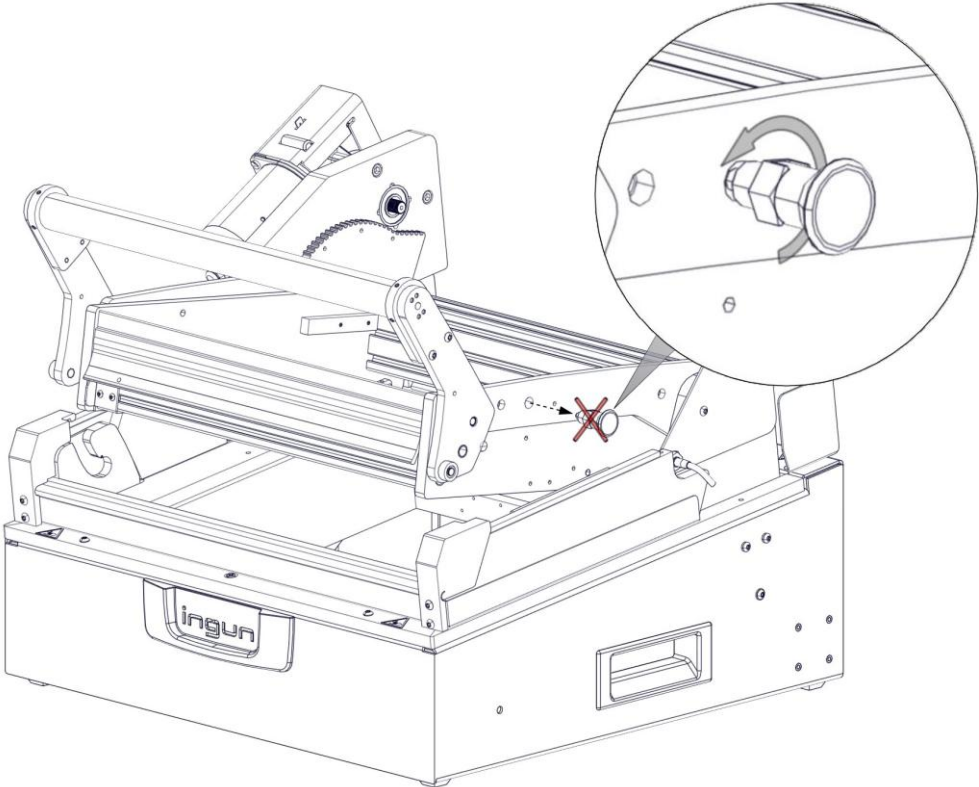

16)

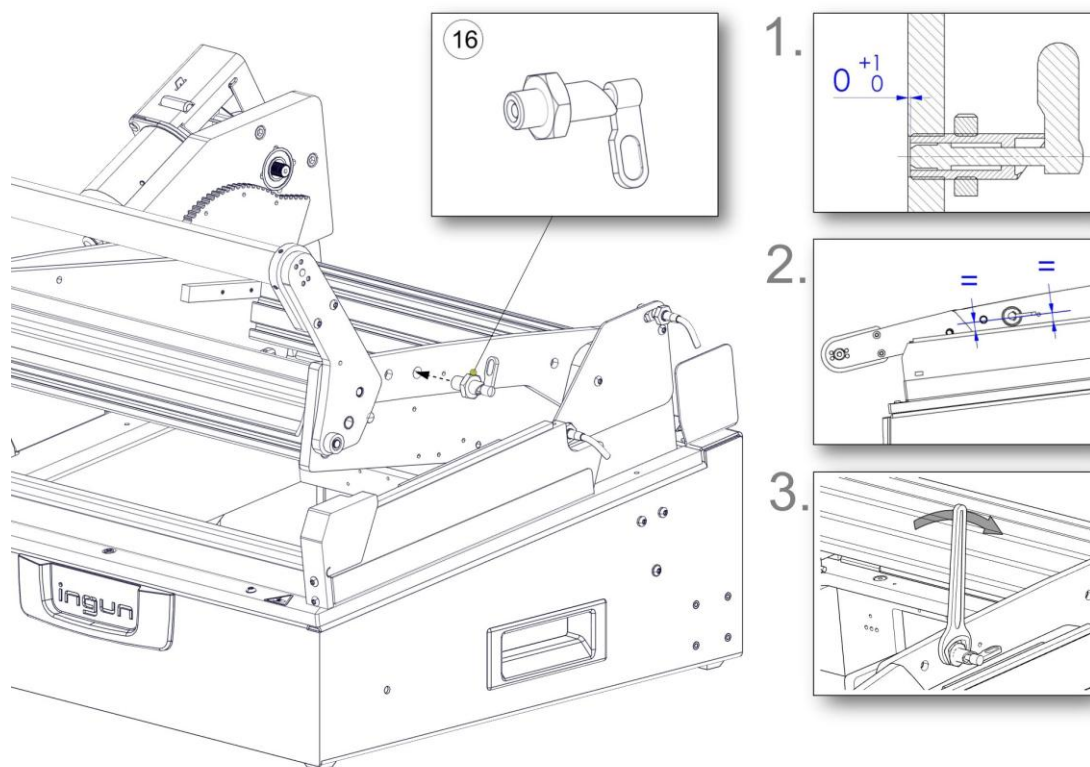

17) **Nach Montage des Zahnrads ist der Prüfadapter betriebsbereit**
After mounting the gear wheel, the test fixture is ready for operation

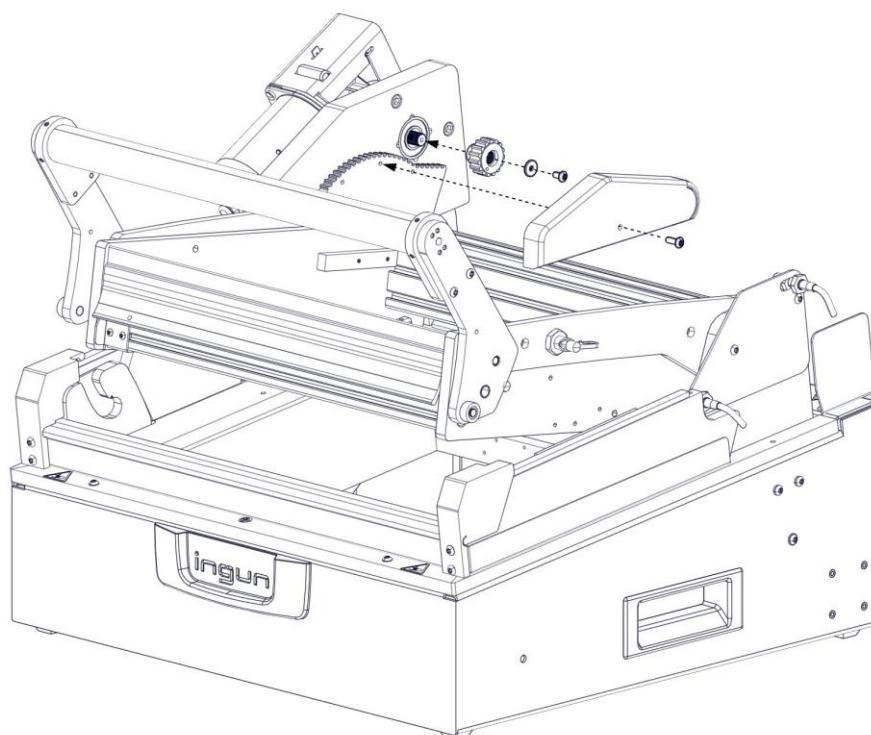

**18) Steuerung nach Referenzdesign INFO-4594 /
Controller based on reference design INFO-4594**

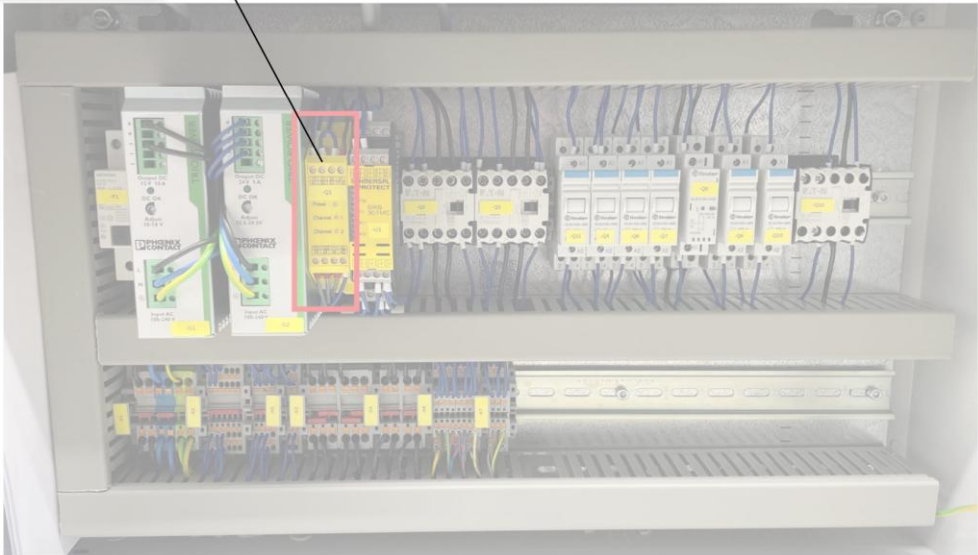
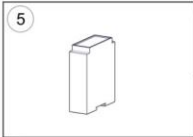

19)

D-SUB 15 pol.

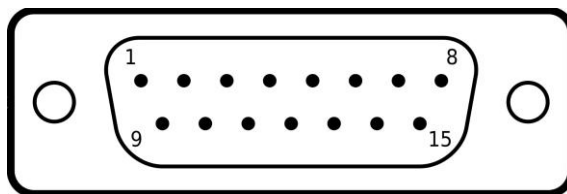

Sicherheits-Schaltleiste /
Safety edge

Schalter Montageplatte /
Switch mounting plate

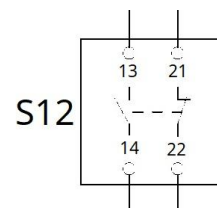
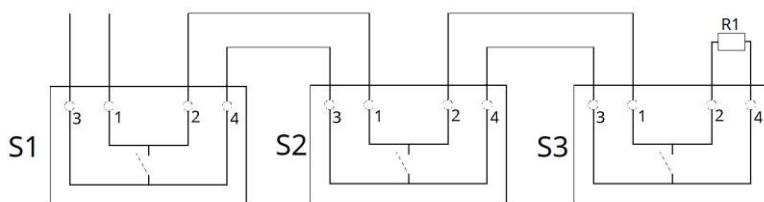

D-SUB-Pin 7	S12-13
D-SUB-Pin 8	S12-14
D-SUB-Pin 9	S12-21
D-SUB-Pin 10	S12-22
D-SUB-Pin 11	S1-1
D-SUB-Pin 12	S1-3

20)

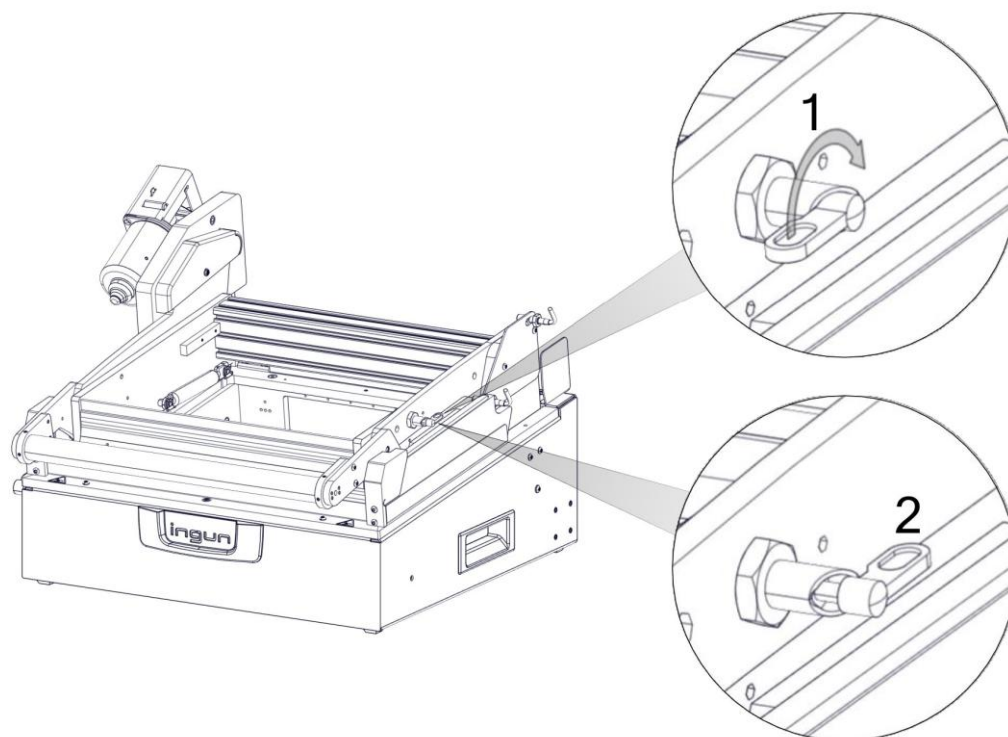

ACHTUNG: Mögliche Beschädigung des Antriebszahnrades!
Bei verriegelter Antriebssperre wird das Antriebszahnrad durch das hohe Anlaufmoment des Motors beschädigt.

⇒ Vor Betätigung der Öffnungs-/Schließautomatik muss die Antriebsverriegelung entriegelt werden!

CAUTION: Possible damage to the drive gear wheel!

When the drive lock is locked, the drive gearwheel will be damaged by the high starting torque of the motor.

⇒ The drive lock must be unlocked before operating the automatic opener/closer!

INGUN Prüfmittelbau GmbH
Max-Stromeyer-Straße 162
D-78467 Konstanz
Tel. +49 7531 8105-0
www.ingun.com