

Extended operating handle

FB-VLK-MA2xxx

Item 43763



GO TO PRODUCT

ingun[®]

Partner for Future Technology

- Upgrade kits to make operation easier, increase the testing reliability, and to reduce handling times
- Available for manual test fixtures and exchangeable kits
- Wide range of varying functions

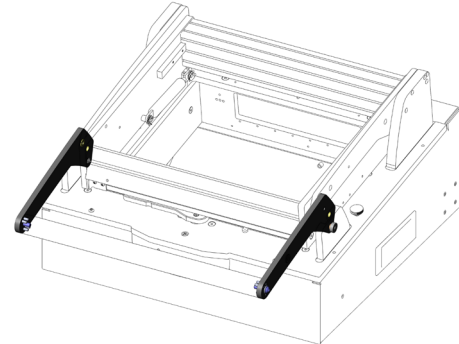

General data

Product group:
Series:
Type:
Version:
Accessory type:
Scope of delivery:
Width:
Height:
RoHS-compliant:

Functional units
FB-MAxxxx
Set
Extended latch
Additional function
2x latch
233.6 mm [9.19 in]
8 mm [.314 in]
Yes

Compatible with

Exchangeable kits version:
Manual test fixtures (MA):

No limitations
MA 2xxx

Technical data

Force: 80 N [287 ozf]
Length: 75.5 mm [2.97 in]
Outer dimensionS (WxDxH): 233.6 x 75.5 x 8 mm [9.19 x 2.97 x .314 in]

INGUN Prüfmittelbau GmbH

Max-Stromeyer-Straße 162
78467, Constance, Germany
Phone +49 7531 8105-0
Customer hotline +49 7531 8105-888
Fax +49 7531 8105-65
info@ingun.com



Prices and delivery times on request.
Technical changes reserved. 05/26_GB

Learn more about
MA functional units



FUNCTIONAL UNIT

ingun.com