

Spring-loaded tooling pin GFS-3,98-SW-12-05,5-B-G

Item 25214



GO TO PRODUCT

ingun[®]

Partner for Future Technology

- Trusted tooling pin for reliable, spring-loaded mounting of the PCB via the guide holes
- High-precision and low-wear
- Optimum tolerance compensation
- Compact design with internal spring

Application

Spring-loaded tooling pins (GFS) are used to spring-load the PCB to be tested via the guide holes and position it precisely in the probe field on the contacting plane.

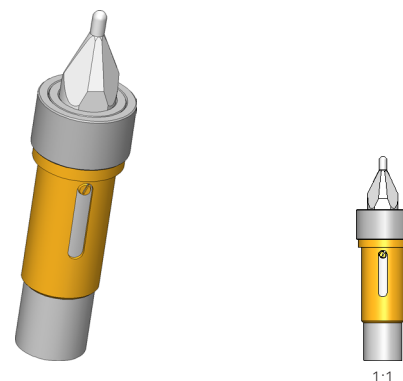

1:1

Note:

The spring-loaded tooling pin is mounted in the moving plate (ADP) and must be positioned with the collar flush to the surface of the moving plate.

Note:

Depending on the shape and tolerance accuracy of the PCB, tooling pin combinations with round/round or round/blade tip styles are used. The long side of the blade must always be aligned perpendicular to the distance of the hole.

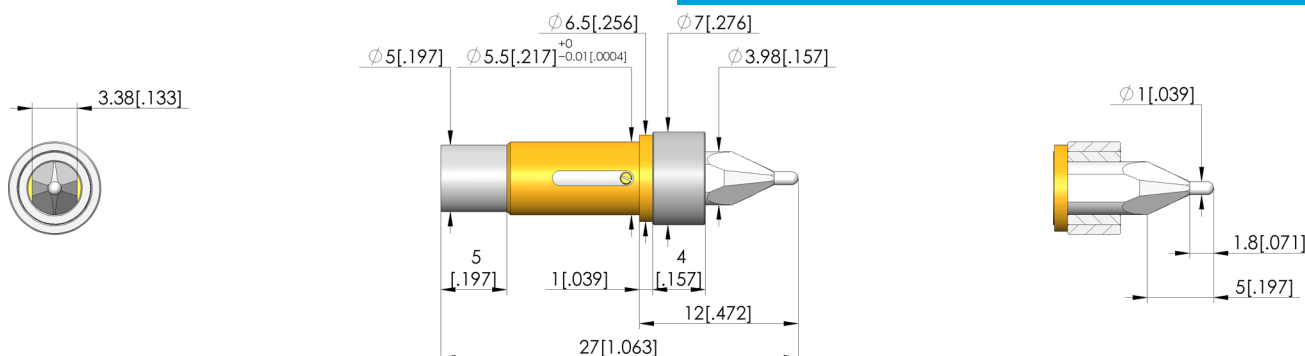

General data

Product group:	Tooling pins
Series:	FS-GF
Type:	Spring-loaded
Version:	Sword with collar (D6.5x1), moving plate (ADP)
Accessory type:	Customising accessories
Scope of delivery:	Incl. friction bearing
Weight:	0.01 kg [.022 lbs]
Min. temperature:	10 °C [50 °F]
Max. temperature:	60 °C [140 °F]
RoHS-compliant:	Yes

Compatible with

Exchangeable kits version:	No limitations
Manual test fixtures (MA):	MA 2012
Vacuum test fixtures (VA):	VA 30xx
MA exchangeable kits (ATS MA):	ATS MAxx
PA exchangeable kits (ATS PA):	ATS PAZxxx
For dual-stage contacting:	Yes

Technical data

Stroke:	5 mm [.196 in]
Tip diameter:	3.98 mm [.156 in]
Force:	3 N [10.7 ozf]
Installation:	Plugged
Spring force:	3 N [10.7 ozf]
Length:	27 mm [1.06 in]
Tip height:	5 mm [.196 in]
Diameter:	7 mm [.275 in]
Pin diameter:	5.5 mm [.216 in]

Spring-loaded tooling pin GFS-3,98-SW-12-05,5-B-G

Item 25214



ingun[®]

Partner for Future Technology

Accessories

Part no.	Designation	Version
24481	GFS-3,98-RD-12-05-B-G	Spring-loaded tooling pin, tip style: round shaped

INGUN Prüfmittelbau GmbH

Max-Stromeyer-Straße 162
78467, Constance, Germany
Phone +49 7531 8105-0
Customer hotline +49 7531 8105-888
Fax +49 7531 8105-65
info@ingun.com



Prices and delivery times on request.
Technical changes reserved. 06/26_GB