

# Automatic opener/closer FB-OSA-E-MA3213/14

Item 114535



GO TO PRODUCT

ingun®

Partner for Future Technology

- Automatic opener/closer to automatise manual test fixtures
- Automated opening, closing, and contacting
- Functional unit for individually configurable upgrading (independent, on-site installation)
- Includes detailed print and video installation documentation

UTILITY  
MODEL

NEW

## Application

Using the automatic opener/closer, manual test fixtures can be upgraded with an electric drive that enables automated opening, closing, and contacting of the manual test fixture. The drive is provided by a DC gearmotor which drives the toothed segment of the drive unit's coupling via a gear wheel.

Upgrading the manual test fixture with the automatic opener/closer results in potential risks for the operator, which must be minimised using suitable protective devices for safe operation. For this purpose, the optionally available safety switch unit can be used. This stops the drive thanks to the safety stop function and provides protection against potential injury.

Both functional units can be operated using customer controls. We provide a reference design document which illustrates a suggestion for connecting the control system.

## Features

- Opening and closing time both approximately 5 seconds
- Compatible with other functional units, according to compatibility matrix
- Optional safety switch unit
- Reference design document which illustrates a suggestion for connecting the automatic opener/closer and the safety switch unit to the control system.
- Manual operation is possible after the cover on the gear wheel are dismantled in accordance with section 6.5 of the user manual, or by using the freewheel clutch #115618 (FB-FK-OSA-E)

## Delivery

The functional unit, which does not include the control system, must be assembled upon delivery using detailed documentation provided. The documentation for the reference design is available to download from our website:

## Spare parts

We recommend checking the gear wheel for wear every 200,000 load cycles and replacing it after the typical service life (500,000 load cycles) has been reached, at the latest.

## Video

Don't miss the videos on our website. The product video provides information about added values and functionalities of the automatic opener/closer. The installation video provides instructions for independent, on-site installation.



### Note:

The automatic opener/closer is approved for use with MA 3213/14 new appliances that were placed on the market from June 2024. If the automatic opener/closer is used for an existing appliance that was placed on the market earlier, adjustments must be made to the rear frame of the existing appliance in the form of reworking. Part#116590 (MTZ-S-NDH-MAxxxx), which is supplied with detailed installation documentation, is used for this purpose.

### Note:

The maximum permissible weight depends on the gas springs used in the drive unit. Gas springs are always required in the system as they support the drive of the automatic opener/closer. This reduces wear on the gear wheel and ensures a long service life. The gas springs should be selected so that the pressure frame opens without the automatic opener/closer, solely by means of the gas springs.

### Note:

To install the automatic opener/closer, refer to installation instructions INFO 4595. Refer to installation instructions INFO 4596 to correctly install the safety switch unit. The reference design for the control of the automatic opener/closer and the safety switch unit, can be found in document INFO 4594.

### Note:

We recommend using the tool #114221 (WZ-AZ-001-FB-OSA-E-MAxxxx) to install the automatic opener/closer according to installation instructions INFO 4595. This tool is used to easily dismantle the block the coupler is pressed onto. The tool is not included in delivery and must be ordered separately.

FUNCTIONAL UNIT

# Automatic opener/closer FB-OSA-E-MA3213/14

Item 114535



GO TO PRODUCT

**ingun**<sup>®</sup>

Partner for Future Technology

## General data

Product group:	Automation
Series:	FB-MAxxxx
Type:	Automatic opener/closer
Version:	Electrical
Accessory type:	Additional function
Scope of delivery:	Unassembled
Width:	672 mm [26.4 in]
Height:	386 mm [15.1 in]
Weight:	3.8 kg [8.37 lbs]
Min. temperature:	10 °C [50 °F]
Max. temperature:	60 °C [140 °F]
RoHS-compliant:	Yes

## Compatible with

Manual test fixtures (MA):	MA 3214
For dual-stage contacting:	No

## Technical data

Connection:	D-sub, 15-pole
Force:	1000 N [3,596 ozf]
Max. voltage:	12 VDC
Pressure frame opening angle:	69 °
Length:	611 mm [24 in]
Outer dimensionS (WxDxH):	672 x 611 x 386 mm [26.4 x 24 x 15.1 in]

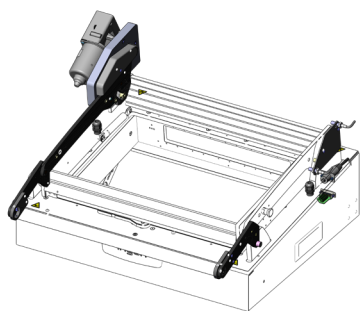

## Accessories, spare part kits & safety components

Part no.	Designation	Version	Compatible with
Accessories			
115618	FB-FK-OSA-E	Freewheel clutch	FB-OSA-E-MAxxxx
114221	WZ-AZ-001-FB-OSA-E-MAxxxx	Tool Pull-off device	FB-OSA-E-MAxxxx
Spare part kits			
114272	ETK-ZAR-Z15-FB-OSA-E-MAxxxx	Spare part kit, gear wheel	FB-OSA-E-MAxxxx
114365	ETK-ABD-FB-OSA-E-MAxxxx	Spare part kit, gear wheel cover	FB-OSA-E-MAxxxx
Safety components			
114287	FB-SIS-OSA-MAxx13	Safety switch	MA 2x13 with FB-OSA-E-MA2x13/14
114826	FB-SIS-OSA-MAxx14	Safety switch	MA 2x14 with FB-OSA-E-MA2x13/14

## INGUN Prüfmittelbau GmbH

Max-Stromeyer-Straße 162  
78467, Constance, Germany  
Phone +49 7531 8105-0  
Customer hotline +49 7531 8105-888  
Fax +49 7531 8105-65  
info@ingun.com



Prices and delivery times on request.  
Technical changes reserved. 06/26\_GB

Learn more about  
MA functional units



FUNCTIONAL UNIT

ingun.com