

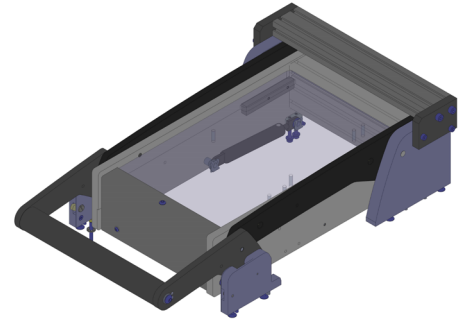

GO TO PRODUCT

- Parallel closing drive mechanism without mounting plate, without internal interface
- High contact force
- Freely configurable signal transmission
- Quick, easy, precise installation
- Can be used for various applications



General data

Product group:	Manual drive unit
Main series:	ATE VAxxxx
Subseries:	ATE VA2xxx
Series:	ATE VA20xx
Size:	2140/2160
Test fixture type:	Without mounting plate
Contact stroke generation:	Manual
Max. contact force:	2000 N [7,193 ozf]
Approx. parallel contact stroke:	15 mm [,59 in]
Min. temperature:	10 °C [50 °F]
Max. temperature:	60 °C [140 °F]
RoHS-compliant:	Yes

Technical data

Pushrod length:	60 mm [2.36 in]
Test probe installation height, top:	16 mm [.629 in]
Free space above PCB:	58 mm [2.28 in]
Pressure frame closing force:	120 N [431 ozf]
Pressure frame opening angle:	69 °
Useable area, standard (WxD):	135 x 260 mm [5.31 x 10.2 in]
Outer dimensions, closed (WxDxH):	250 x 454 x 101 mm [9.84 x 17.8 x 3.97 in]

INGUN Prüfmittelbau GmbH

Max-Stromeyer-Straße 162
78467, Constance, Germany
Phone +49 7531 8105-0
Customer hotline +49 7531 8105-888
Fax +49 7531 8105-65
info@ingun.com



Learn more about
Test fixture kits

